

Autonics

**Photoelectric Sensor
BUP SERIES**

INSTRUCTION MANUAL



Thank you for choosing our Autonics product.
Please read the following safety considerations before use.

■ Safety Considerations

※Please observe all safety considerations for safe and proper product operation to avoid hazards.

※⚠ symbol represents caution due to special circumstances in which hazards may occur.

⚠ Warning Failure to follow these instructions may result in serious injury or death.

⚠ Caution Failure to follow these instructions may result in personal injury or product damage.

⚠ Warning

- Fail-safe device must be installed when using the unit with machinery that may cause serious injury or substantial economic loss.** (e.g. nuclear power control, medical equipment, ships, vehicles, railways, aircraft, combustion apparatus, safety equipment, crime/disaster prevention devices, etc.)
Failure to follow this instruction may result in personal injury, economic loss or fire..
- Do not use the unit in the place where flammable/explosive/corrosive gas, high humidity, direct sunlight, radiant heat, vibration, impact, or salinity may be present.**
Failure to follow this instruction may result in explosion or fire.
- Do not disassemble or modify the unit.**
Failure to follow this instruction may result in fire.
- Do not connect, repair, or inspect the unit while connected to a power source.**
Failure to follow this instruction may result in fire.
- Check 'Connections' before wiring.**
Failure to follow this instruction may result in fire.

⚠ Caution

- Use the unit within the rated specifications.**
Failure to follow this instruction may result in fire or product damage.
- Use dry cloth to clean the unit, and do not use water or organic solvent.**
Failure to follow this instruction may result in fire.

■ Ordering Information

BUP-50S-P	Control output	No mark	NPN open collector output
		P	PNP open collector output
	Sensitivity adjustment	No mark	Fixed sensitivity type
		S	Adjustable sensitivity VR built-in type
	Sensing distance	30	30mm
		50	50mm
	tem	BUP	Photoelectric sensor

■ Operation Mode

Operation mode	Light ON	Dark ON
Receiver operation	Received light Interrupted light	
Operation indicator	ON OFF	
Transistor output	ON OFF	

※The above specifications are subject to change and some models may be discontinued without notice.
※Be sure to follow cautions written in the instruction manual and the technical descriptions (catalog, homepage).

■ Specifications

Model	NPN open collector	BUP-30	BUP-30S	BUP-50	BUP-50S
	PNP open collector	BUP-30-P	BUP-30S-P	BUP-50-P	BUP-50S-P
Sensing type	Through-beam				
Sensing target	Min. ø4mm Opaque material		Min. ø1.5mm Opaque material	Min. ø4mm Opaque material	Min. ø1.5mm Opaque material
Operation mode	Selectable Light ON or Dark ON by control wire				
Sensing distance	30mm				
Response time	Max. 1ms				
Power supply	12-24VDC±10%(Ripple P-P:Max. 10%)				
Current consumption	Max. 30mA				
Light source	Infrared LED(940nm)				
Sensitivity adjustment	Fixed	Adjustable VR	Fixed	Adjustable VR	
Control output	NPN or PNP open collector output • Load voltage: Max. 30VDC±, • Load current: Max. 200mA, • Residual voltage-NPN: Max. 1VDC±, PNP: Max. 2.5VDC				
Protection circuit	Reverse polarity protection, Short output circuit protection				
Indicator	Power indicator : Green LED, Operation indicator : Red LED				
Insulation resistance	Min. 20MΩ(at 500VDC megger)				
Noise resistance	±240V the square wave noise(pulse width:1μs) by the noise simulator				
Dielectric strength	1000VAC 50/60Hz for 1minute				
Vibration	1.5mm amplitude at frequency of 10 to 55Hz(for 1 min.) in each of X, Y, Z directions for 2 hours				
Shock	500m/s ² (50G) in X, Y, Z directions for 3 times				
Environ-ment	Ambient illumination	Sunlight: Max. 11,000lx Incandescent lamp : Max. 3,000lx			
	Ambient temperature	-25 to 65°C[BUP-30S(-P) & BUP-50S(-P) : -10 to 60°C], Storage : -25 to 70°C			
	Ambient humidity	35 to 85%RH, Storage: 35 to 85%RH			
Protection	IP66(IEC standard)	IP50(IEC standard)	IP66(IEC standard)	IP50(IEC standard)	
Material	Case: ABS, Cap: PC				
Cable	ø4, 4-wire, Length: 2m(AWG22, Core diameter: 0.08mm, Number of cores:60, Insulator diameter:1.25mm)				
Accessories		Adjustment driver		Adjustment driver	
Approval	CE				
Unit weight	Approx. 90g			Approx. 140g	

※The temperature or humidity mentioned in Environment indicates a non freezing or condensation environment.

■ Dimensions

●BUP-30, BUP-30-P, BUP-30S, BUP-30S-P

(Unit:mm)

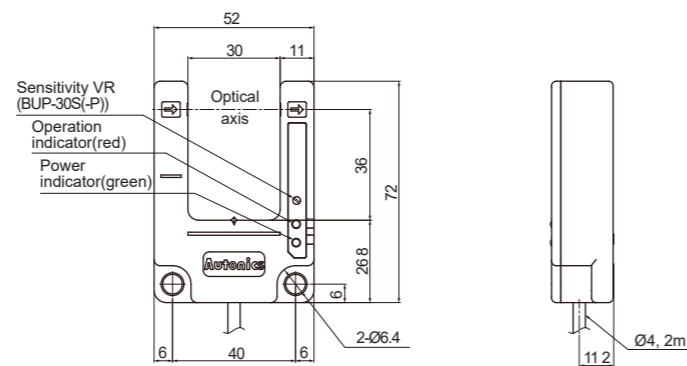

●BUP-50, BUP-50-P, BUP-50S, BUP-50S-P

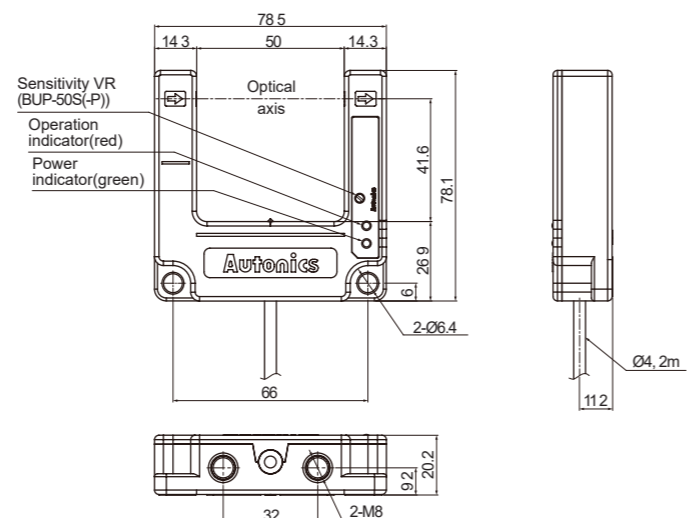

■ Connection

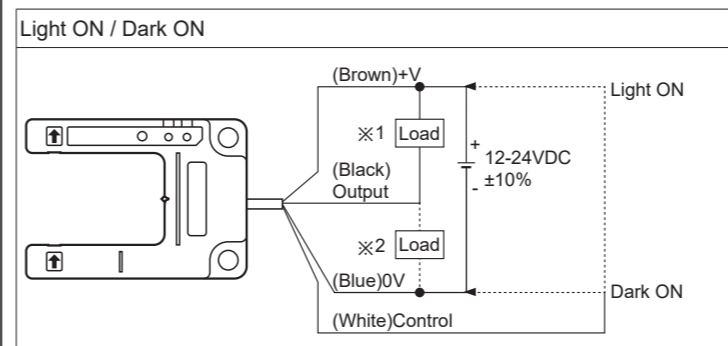

※1: Load connection for NPN open collector output
※2: Load connection for PNP open collector output

■ Control Output Circuit Diagram

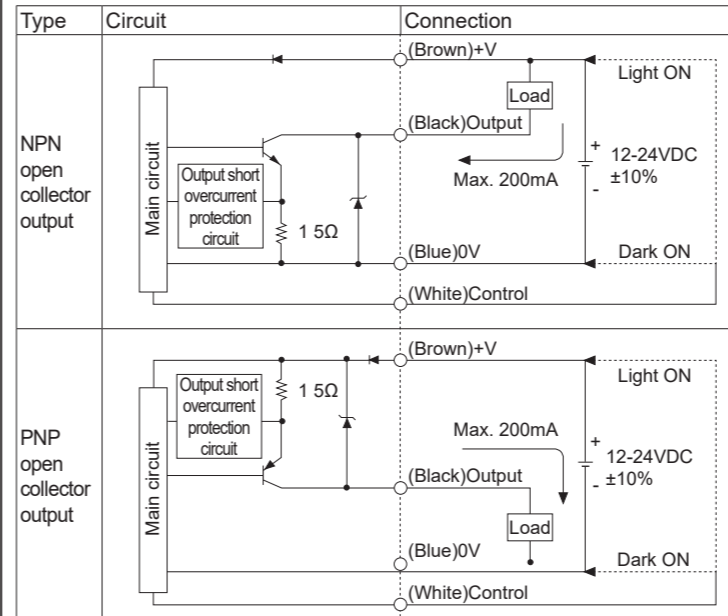

※If short-circuit the control output terminal or supply current over the rated specification, normal control signal is not output due to the output short over current protection circuit.

■ Mounting & Adjustment

Check the position where the photoelectric sensor will be used and the connection then supply the power and set sensitivity as below.

※BUP-30: When installing the product, tighten the screw with a tightening torque of 1.96N.m.

BUP-50: When installing the product, tighten the screw with a tightening torque of 4.9N.m.

●Sensitivity adjustment

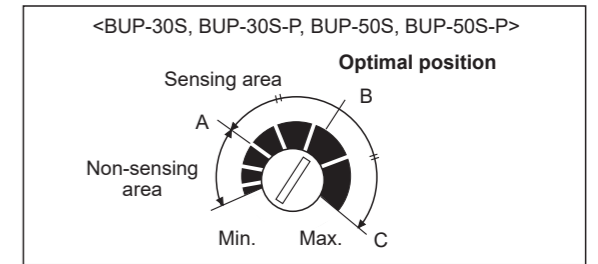

When place a target within sensing range of sensor, turn the VR from the minimum position and check the position 'A' where the operation indicator is turned on (Dark ON) or turned off (Light ON).

Turn the VR to 'B' in the middle between 'A' and 'C' which is the maximum sensitivity position, this will be the optimal sensitivity position.(The operation indicator is able to be operated where the the lowest sensitivity position.)

■ Cautions during Use

- Follow instructions in 'Cautions during Use'. Otherwise, it may cause unexpected accidents.
- When connecting a DC relay or other inductive load to the output, remove surge by using diodes or varistors.
- Use the product, 0.5 sec after supplying power.
When using separate power supply for the sensor and load, supply power to sensor first.
- 12-24VDC power supply should be insulated and limited voltage/current or Class 2, SELV power supply device.
- Wire as short as possible and keep away from high voltage lines or power lines, to prevent inductive noise.
- When using switching mode power supply to supply the power, ground F.G. terminal and connect a condenser between 0V and F.G. terminal to remove noise.
- When using sensor with the equipment which generates noise (switching regulator, inverter, servo motor, etc.), ground F.G. terminal of the equipment.
- This unit may be used in the following environments.
 - ①Indoors (in the environment condition rated in 'Specifications')
 - ②Altitude max. 2,000m
 - ③Pollution degree 2
 - ④Installation category III

■ Major Products

- Photoelectric sensors
- Fiber optic sensors
- Door sensors
- Door side sensors
- Area sensors
- Proximity sensors
- Pressure sensors
- Rotary encoders
- Connector/Sockets
- Temperature controllers
- Temperature/Humidity transducers
- SSR/Power controllers
- Counters
- Timers
- Panel meters
- Tachometer/Pulse(Rate) meters
- Display units
- Sensor controllers
- Switching mode power supplies
- Control switches/Lamps/Buzzers
- I/O Terminal Blocks & Cables
- Stepper motors/drivers/motion controllers
- Graphic/Logic panels
- Field network devices
- Laser marking system(Fiber, CO₂, Nd:YAG)
- Laser welding/Cutting system